



Riverside

TOOL CORP.

P.O. Box 1425 • Elkhart, Indiana 46515
1-800-430-8498 • Ph: 574-522-6798 • Fax: 574-522-6712

CUSTOMER INFORMATION

COMPANY _____
CONTACT PERSON (PRINT) _____
SIGNATURE _____ DATE _____

SAWBLADE SPECIFICATION SHEET

MACHINE

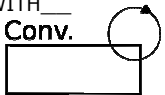
MANUFACTURER _____
TYPE _____
BRAND _____
RPM _____
FEED AUTOMATIC _____ MANUAL _____
FLANGE DIAM _____
FEED DIRECTION
AGAINST _____ WITH _____
Climb  Conv. 

TOOL

DIAMETER _____
TEETH WIDTH _____
BORE DIAMETER _____
KEYWAY _____
CUTTING MATERIAL
CARBIDE _____ DIAMOND _____ RIVERLOY _____

SKETCH

(IF SHOWING TIPS, DRAW FACE COMING)

APPLICATION / MATERIAL

SAMPLE SUPPLIED? YES _____ NO _____
MATERIAL DIMENSION _____
DESCRIPTION OF MATERIAL

CUTTING HEIGHT _____ MM/IN
CUTTING METHOD
SINGLE PIECE _____ STACKED _____
CUTTING QUALITY
ROUGH _____ FINE _____ ULTRA FINE _____
SOLID WOOD
ALONG GRAIN _____ ACROSS GRAIN _____
PANEL MATERIALS
SIZING _____ SQUARE-CUTTING _____

ADDITIONAL INFORMATION

GRIND OF TEETH _____
NUMBER OF TEETH _____
HOOK _____
TYPE OF BODY _____
PLATE THICKNESS _____
EXPANSION SLOTS:
REGULAR _____ LASER _____ COPPER PLUG _____
PINHOLES
NUMBER _____ BOLT CIRCLE _____
HOLE DIA. _____
COUNTERSINK? YES _____ NO _____
SCREW SIZE _____
DIRECTION OF ROTATION LEFT _____ RIGHT _____
RECESSED SAW BODY
HUB DIAMETER _____
HUB THICKNESS _____

NOTES

